



# Control<sup>®</sup> 28

High Output  
Indoor/Outdoor  
Background/Foreground Speaker

## Professional Series

### Key Features:

- ▶ Components: 8" Polypropylene coated woofer, 1" Titanium coated horn loaded tweeter.
- ▶ Built-in *InvisiBall™* mounting hardware\*
- ▶ Weather resistant enclosure and transducers
- ▶ Readily paintable
- ▶ 90° x 90° high frequency horn
- ▶ Overload Protection Circuitry
- ▶ Sensitivity: 92 dB SPL, 1W, 1m

\*Patents pending worldwide

The Control<sup>®</sup> 28 is the largest of JBL Professional's Control Contractor Series indoor/outdoor loudspeakers. Its rich sonic character makes the Control<sup>®</sup> 28 a perfect choice for restaurants, health clubs, under balcony, outdoor theme & water parks, or other applications where foreground/background music and paging are required.

The unique and global patent pending *InvisiBall™* mounting hardware is included in each system and makes short work of permanent installation. The *InvisiBall™* mounting method adds the benefit of vertical rotation of up to 37° off-axis and horizontal rotation of up to 44° off-axis. Because *InvisiBall™* adjustments are made through a hidden access behind the logo badge, the grill never needs to be removed and there exists a high degree of theft deterrence as well.

The Control<sup>®</sup> 28 readily accepts a variety of paints and finishes to match any decor.

Weather resistance is maximized by coating the woofer cone in polypropylene and terminating its circumference in JBL's *WeatherEdge™*, a seamless, rubberized extension of the woofer surround that provides added protection to critical transducer elements. The polycarbonate tweeter diaphragm is reinforced with a thin film of titanium for added rigidity and endurance against sun, salt and moisture. Zinc plated grilles resist rusting in the harshest conditions.

Available in black (Control 28) and white (Control 28-WH).



### Specifications:

|  |  |
|--|--|
| Frequency Range (-10 dB) <sup>1</sup> :          | 60Hz to 16kHz  |
| Continuous Program Power Capacity <sup>2</sup> : | 175 Watts  |
| Sensitivity <sup>3</sup> :                       | 92 dB SPL, 1W, 1m  |
| Directivity Factor (Q):                          | 7.5  |
| Directivity Index (DI):                          | 8.8  |
| Nominal Impedance:                               | 8 ohms   |
| Crossover Frequency:                             | 2.8kHz   |
| LF Driver:                                       | 200mm (8 in) Polypropylene cone w/WeatherEdge  |
| HF Driver:                                       | 25mm (1 in) Titanium coated polycarbonate  |
| Enclosure Material:                              | HIPS (High Impact Polystyrene)   |
| Overload Protection:                             | Full-Range power limiting to protect network and transducers   |
| Termination:                                     | Spring terminals, accepts banana plug  |
| Environmental:                                   | Conforms to Mil Spec 810 for humidity, salt spray, temperature & UV. IEC 529 IP-X4 splashproof rating. |
| Dimensions (H x W x D):                          | 380 x 280 x 220 mm (15.0 x 11.0 x 8.6 in)  |
| Net Weight (ea):                                 | 5.5kg (12 lbs)   |
| Shipping Weight (pr):                            | 11kg (25 lbs)  |
| Included Accessories:                            | Invisiball Assembly<br>6mm x 180mm hex key   |
| Optional Accessories:                            |  |
| MTC-28V:   | For vertical columnar orientation of up to 3 loudspeakers  |
| MTC-28H:   | For horizontal splaying of two speakers. Three brackets array up to six loudspeakers in a 360° array.  |
| MTC-28/25CM:                                     | Ceiling-mount adapter.   |

<sup>1</sup>Half-space (on-wall).

<sup>2</sup>Continuous program power is a conservative expression of the system's ability to handle normal speech and music program material and is defined as 3dB above the Continuous Pink Noise Rating (IEC-shaped pink noise with a 6dB crest factor, for 100 hours continuously).

<sup>3</sup>Half-space (on-wall), ave 100Hz to 10 kHz.

JBL continually engages in research related to product improvement. Changes introduced into existing products without notice are an expression of that philosophy.

# ▶ Control® 28 High Output Indoor/Outdoor Background/Foreground Speaker

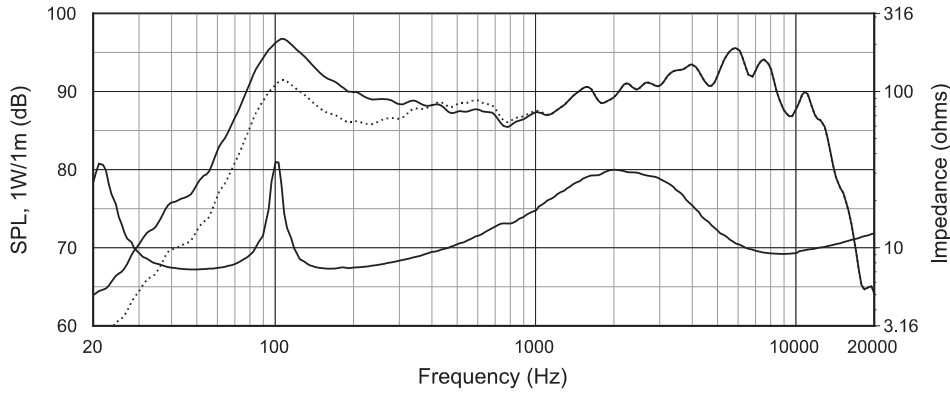

Frequency Response in half-space ( $2\pi$ , solid line) and full-space ( $4\pi$ , dotted line), and Input Impedance

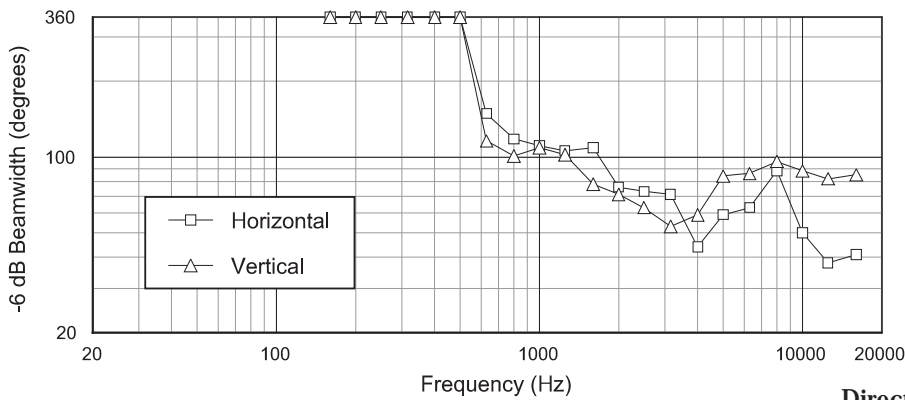

Beamwidth

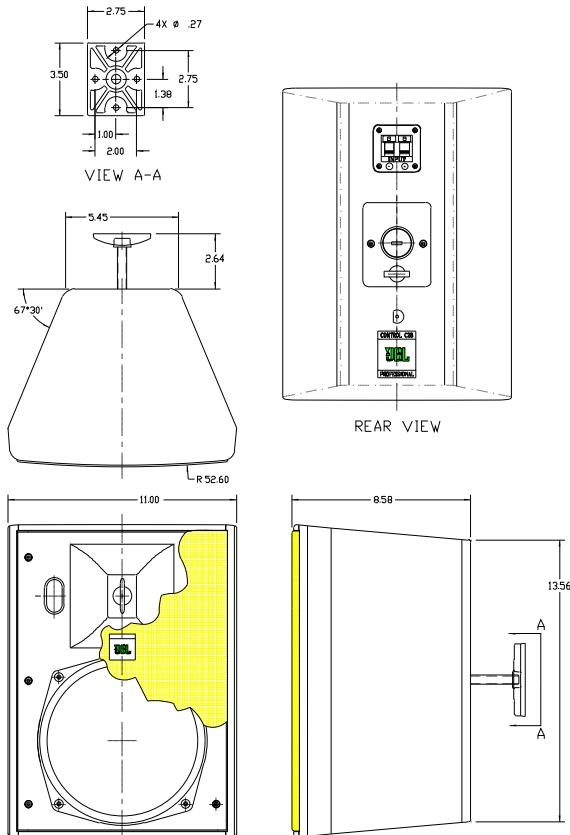

Directivity Index, Q

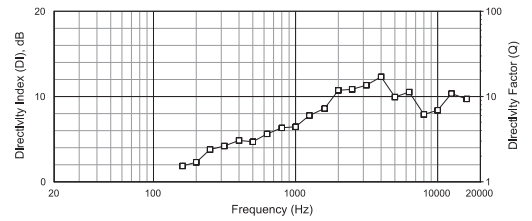

Horizontal Off Axis Frequency Response

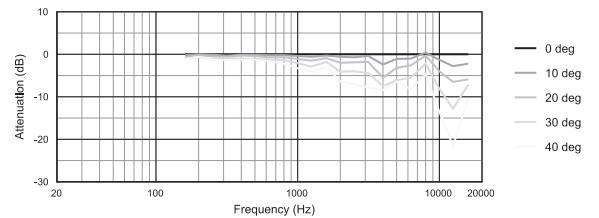

Vertical Off Axis Frequency Response (up)

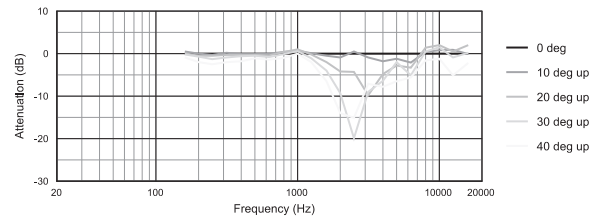

Vertical Off Axis Frequency Response (down)

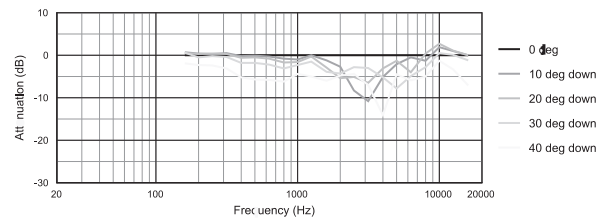

## Horizontal 1/3 Octave Polars

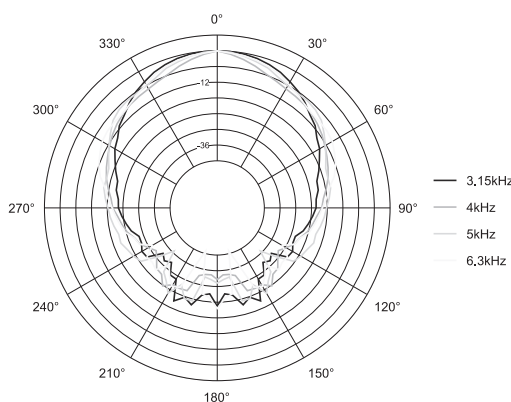
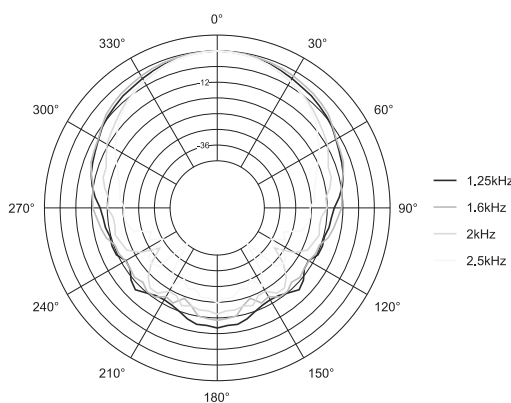
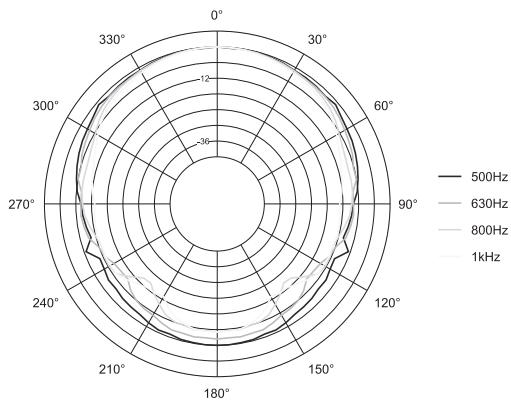
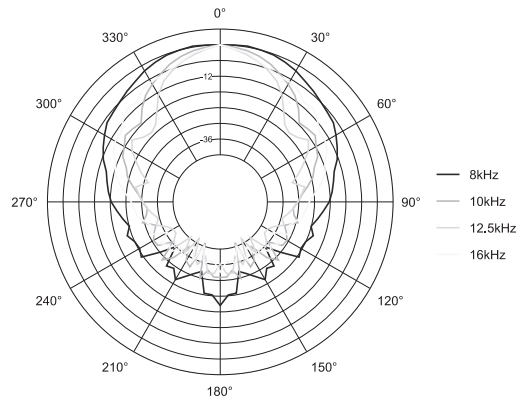
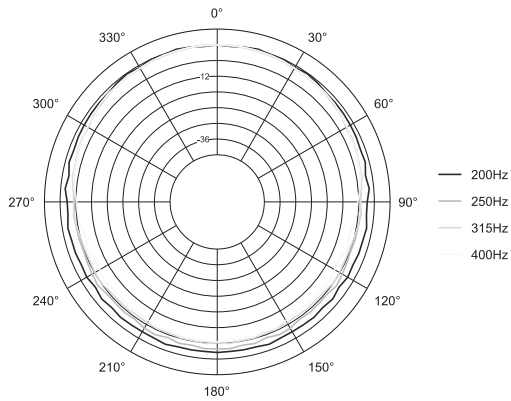

## Architectural Specifications:

The loudspeaker shall consist of a 200mm (8 in) low frequency transducer, 25mm (1 in) high frequency transducer, and frequency dividing network installed in a ported enclosure. The low frequency voice coil shall be 32 mm (1-1/4 in) in diameter.

Performance specifications of a typical production unit shall be as follows: Measured sensitivity (SPL at 1 m [3.3ft] with 2.83V input, averaged from 500 Hz to 1.5 kHz) shall be at least 92 dB-SPL. Usable frequency response shall extend from 60 Hz to 16 kHz (10 dB below rated sensitivity, in half-space, with no external equalization). Nominal impedance shall be 8 ohms. The frequency dividing network shall have a crossover frequency of 2.8 kHz. Rated power capacity shall be at least 175 watts continuous program power, defined as 3dB above a test signal of filtered random noise conforming to international standard IEC268-5 (shaped pink noise with a peak-to-average ratio of 6dB), for 100 continuous hours duration.

The system shall be protected against damage from occasional over-powering via full range series lamps that limits the power to the network and transducers. The high frequency transducer shall be horn-loaded to more evenly cover a nominal 90° horizontal by 90° vertical area.

The enclosure shall be constructed of high-impact polystyrene for protection against the elements in outdoor applications, and for paintability. The grille shall be completely zinc-coated for resistance against rusting, shall be bake-painted black, and shall be secured via screws to keep it in place when facing downward.

The low frequency transducer shall have a polypropylene cone and a butyl rubber surround which shall extend seamlessly over the edge of the speaker frame for protection against the elements. The high frequency transducer shall be constructed of polycarbonate, reinforced with a titanium film for additional weather resistance. The system shall withstand Mil Spec 810 testing with specified time durations for exposure to the following environments with no effect on its acoustical performance or structural integrity: salt spray (method 509.3), temperature -19°C to 49°C (method 501.3 and 502.3), 95% humidity (method 507.3) and ultraviolet (method 505.3). The system shall have a IEC 529 splashproof rating of IP-X4.

For theft deterrence, the installation access area shall be hidden behind a snap-out cover, and the access area shall be on the front of the loudspeaker for ease of installation and adjustment. The loudspeaker shall be rotatable over a minimum of  $\pm 35^\circ$  in all directions via a ball-type mounting system. The ball mechanism shall be internal to the cabinet to allow low-profile mounting and better stability via a short moment arm. The logo shall be rotatable for proper orientation when the loudspeaker is mounted horizontally or vertically.

The external wiring connectors shall be spring loaded and gold plated, and shall accept bare wire, single or dual banana-type connectors with 19 mm (3/4 in) spacing. Overall cabinet dimensions shall be no greater than 380 mm (15.0 in) high by 280 mm (11.0 in) wide by 220 mm (8.6 in) deep and shall weigh no more than 5.5 kg (12 lbs). The finish shall be a paintable lightly textured black.

The system shall be the JBL Model Control 28 with included Invisiball™ mounting system.

# ▶ Control® 28 High Output Indoor/Outdoor Background/Foreground Speaker

## Vertical 1/3 Octave Polars

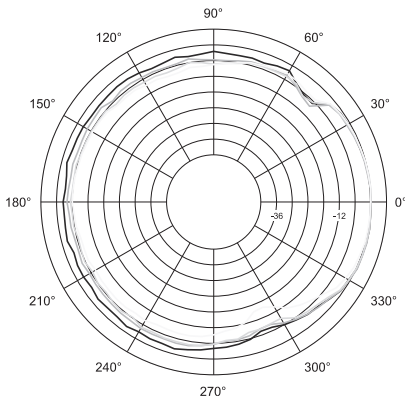

- 200Hz
- 250Hz
- 315Hz
- 400Hz

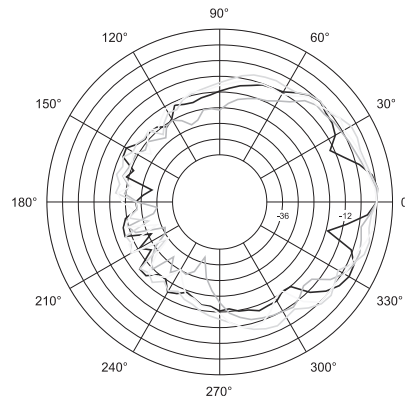

- 3.15kHz
- 4kHz
- 5kHz
- 6.3kHz

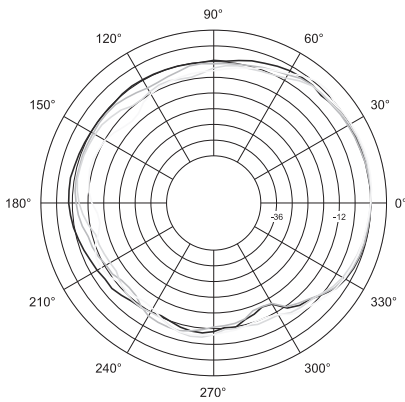

- 500Hz
- 630Hz
- 800Hz
- 1kHz

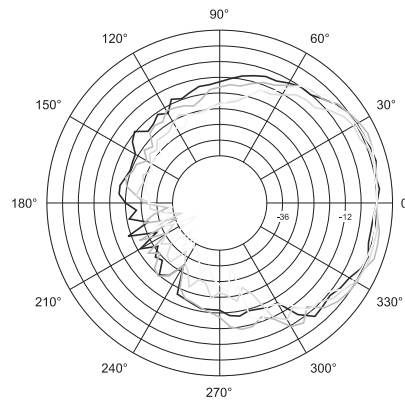

- 8kHz
- 10kHz
- 12.5kHz
- 16kHz

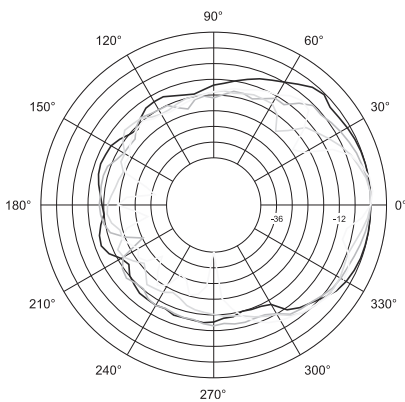

- 1.25kHz
- 1.6kHz
- 2kHz
- 2.5kHz

*CCI Solutions*  
be seen. be heard.

For more information or to order call  
**1-800-426-8664** or visit [www.ccisolutions.com](http://www.ccisolutions.com)

SS Control 28  
CRP 20M  
5/97